

## 230 Eclipse Squeeze Slam Latch

### Features

- Squeeze latch design with slam bolt on side, the Eclipse® squeeze latch features a distinctive “pinch” method of activation for specialized use in such applications as electronic, food service and medical enclosures
- Produced with UV stabilized thermoplastic and stainless steel components, latch is suitable for extreme applications that deal with water including boats, campers, trailers, or outdoor containers
- Easy installation with the use of the mounting bracket and 2 screws, which are provided. No external fasteners required and no weld marks to mar finish
- Eclipse latches can be assembled on finished panels. An oil-resistant flange gasket is also provided
- Key-locking version is furnished with two keys

### Material

- Squeeze latch and housing are manufactured from high strength, UV stabilized thermoplastic
- Metal stampings are 300 Series stainless
- Key cylinder is zinc die cast

### Notes

- Striker (ECL-19) also available as separate order

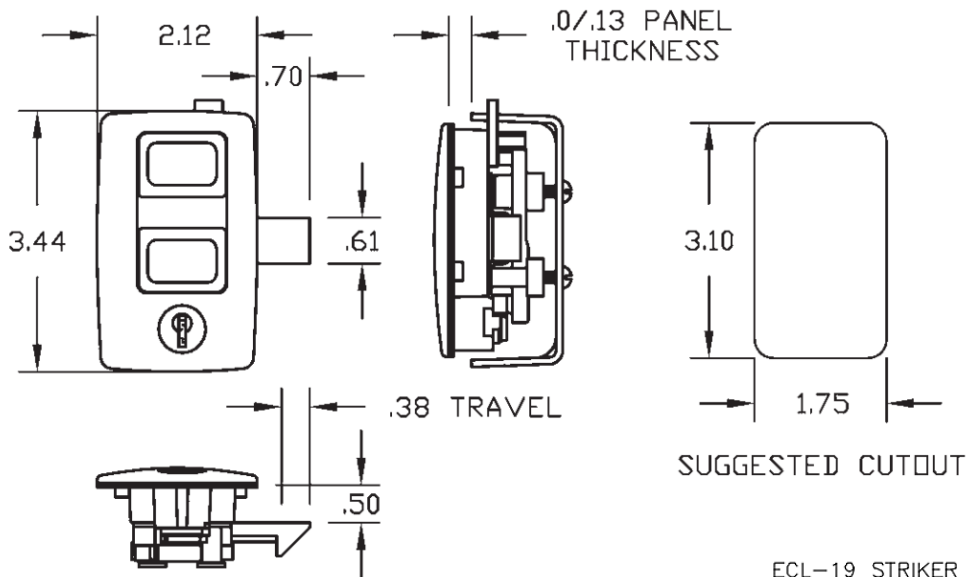

ECL-19 STRIKER  
(ORDER SEPERATELY)

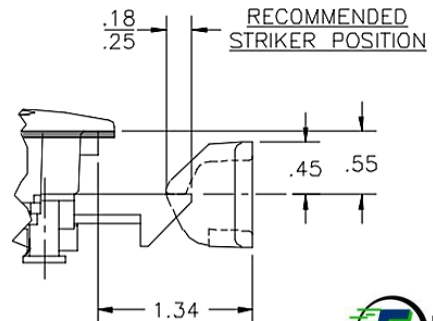

Part No.	Type	Finish
ECL-230-P8-MB	Non-Locking	Matt Black
ECL-230-P8-MW		Matt White
ECL-230-KP8-MB	Key Locking	Matt Black
ECL-230-KP8-MW		Matt White

Dimensions in inches